

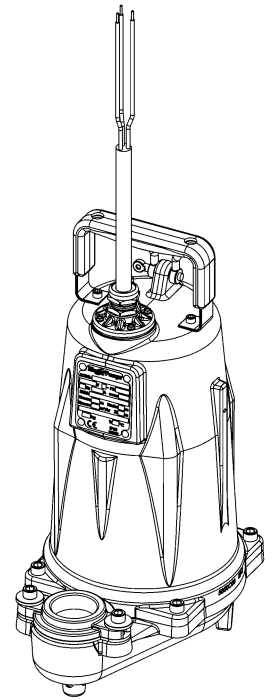

Pump Specifications

FL200-E Series Submersible Effluent Pump



50Hz Hydraulic Performance

3/4" Solids Handling Effluent Pumps

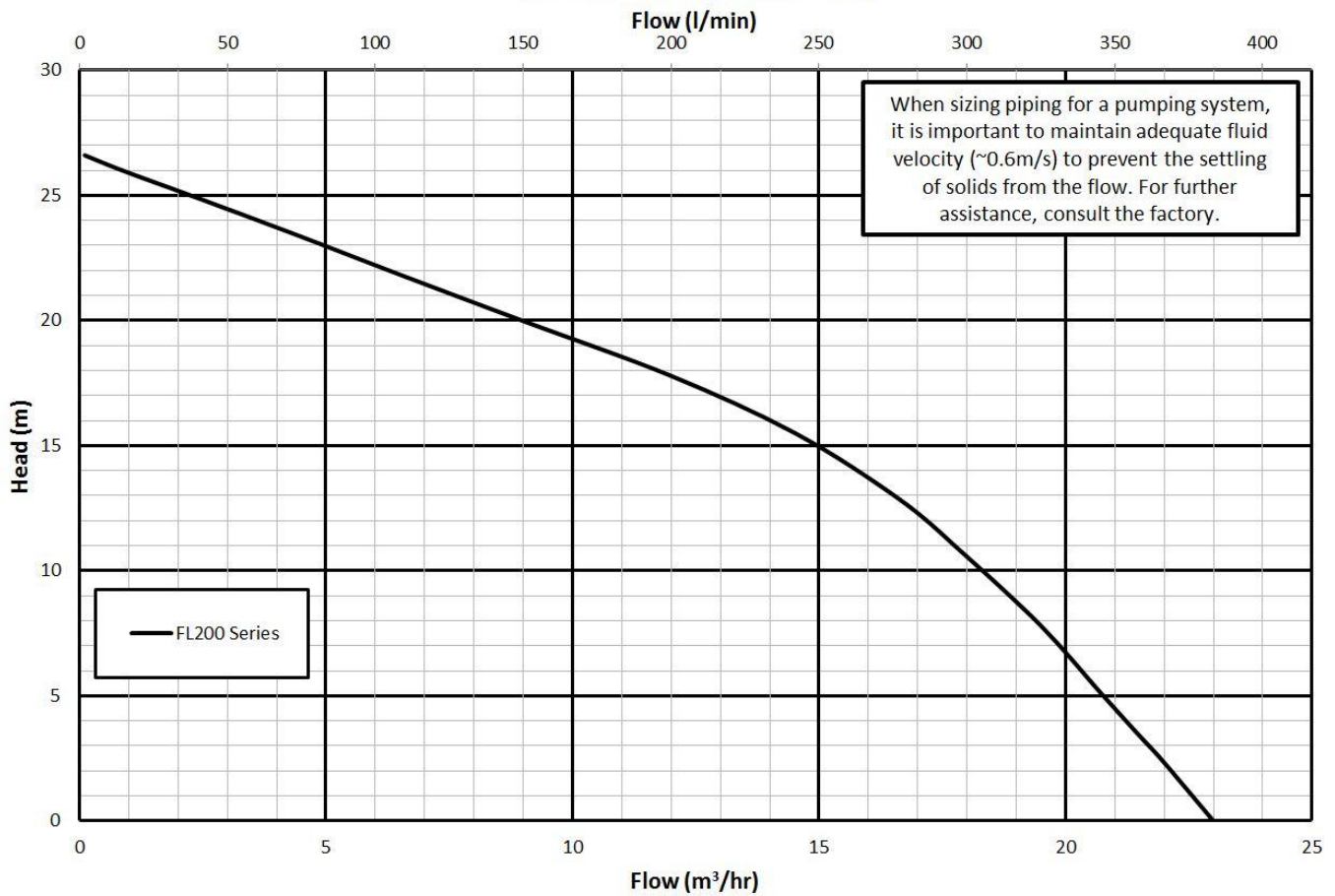

FL200-E Series Dimensional Data

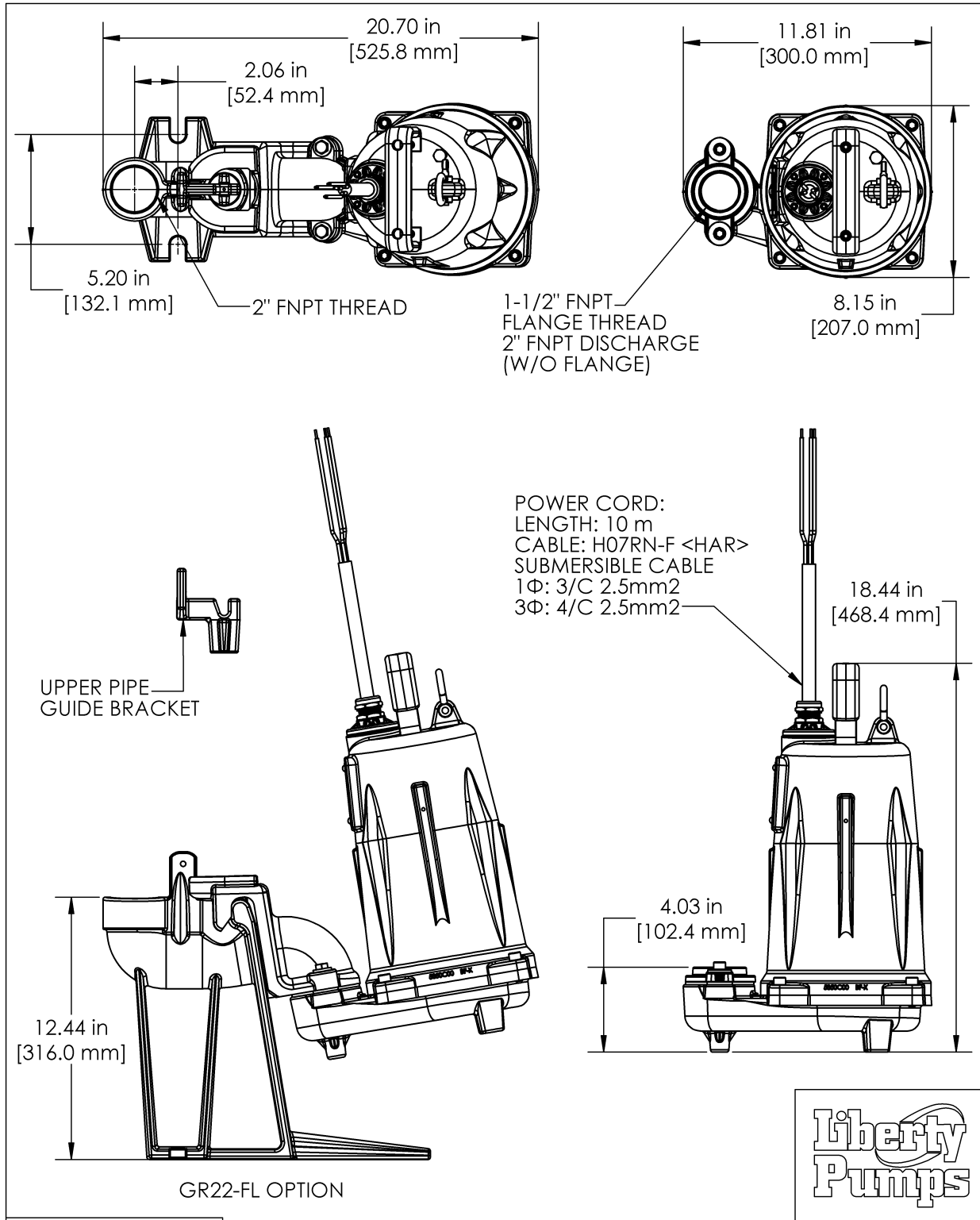

PROPRIETARY AND CONFIDENTIAL
 THE INFORMATION CONTAINED IN THIS DRAWING IS THE SOLE PROPERTY OF LIBERTY PUMPS. ANY REPRODUCTION IN PART OR AS A WHOLE WITHOUT THE WRITTEN PERMISSION OF LIBERTY PUMPS IS PROHIBITED.

APPLICATION	DO NOT SCALE DRAWING
-------------	----------------------

FL200 -E SERIES DIMENSIONAL		
DWG. NO.		
SIZE A	DATE:	REV. A
SCALE:1:4	WEIGHT: 37 kg	SHEET 1 OF 1

FL200-E Series Electrical Data

MODEL	kW	HP	VOLTAGE	PHASE	SF	FULL LOAD AMPS	LOCKED ROTOR AMPS	THERMAL OVERLOAD TEMP	STATOR WINDING CLASS	CORD LENGTH (M)	DISCHARGE (FNPT)
FL202M-3E	1.5	2	230	1	1.00	11.1	48	135° C	B	10	1.5 OR 2"
FL203M-3E	1.5	2	230	3	1.00	13.2	68	N/A	B	10	1.5 OR 2"
FL204M-3E	1.5	2	400	3	1.00	4.5	32	N/A	B	10	1.5 OR 2"

Notes:

1. All FL200M-3E pumps are manual models and have 10 m bare lead power cords.
2. The voltages of 230 and 400 mentioned above are EN harmonized voltages and cover system voltages 220-240 and 380-415, respectively.

FL200-E Series Technical Data

IMPELLER	2 VANE CLASS 25 CAST IRON 3/4" (19,1 mm) SOLIDS HANDLING
PROTECTIVE COATING	POWDER COAT EPOXY
MAX LIQUID TEMP	140°F / 60°C
MAX STATOR TEMP	275°F / 135°C
THERMAL OVERLOAD	275°F / 135°C (single phase only)
POWER CORD TYPE	H07RN-F
MOTOR HOUSING	CLASS 25 CAST IRON
VOLUTE	CLASS 25 CAST IRON
SHAFT	STAINLESS
HARDWARE	STAINLESS
ORINGS	BUNA-N
MECHANICAL SEAL	UNITIZED SILICON CARBIDE
WEIGHT	40 kg
CARTON DIMENSIONS (cm)	37 W, 25.5 D, 57.5 T

FL200-E Series Specifications

1.01 GENERAL:

The contractor shall provide labor, material, equipment, and incidentals required to provide _____ (QTY) centrifugal effluent pumps as specified herein. The pump models covered in this specification are FL200-E Series single phase or three phase effluent pumps. The pump furnished for this application shall be model _____ as manufactured by Liberty pumps.

2.01 OPERATING CONDITIONS:

Each submersible pump shall be rated at 1.5 kW _____ volts _____ phase 50 Hz. 2875 RPM. The unit shall produce _____ m³/hr at _____ meters of total dynamic head.

The submersible pump shall be capable of handling 3/4" (19.1 mm) solids enabling pumping over long distances in pipelines as small as 1.5" (38,1 mm) in diameter. The submersible pump shall have a shut-off head of 26.5 meters and a maximum flow of 21.5 m³/hr @ 3.3 meters of total dynamic head.

3.01 CONSTRUCTION:

Each centrifugal effluent pump shall be equal to the  certified Series FL200 effluent pumps as manufactured by Liberty Pumps, Bergen NY. The castings shall be constructed of class 25 cast iron. The motor housing shall be oil filled to dissipate heat. Air filled motors shall not be considered equal since they do not properly dissipate heat from the motor. All mating parts shall be machined and sealed using Buna-N rubber. All fasteners exposed to the liquid shall be stainless steel.

The motor shall be protected on the top side with an IP68 rated cord system, eliminating the ability of water to enter internally through the cord. The motor shall be protected on the lower side with a dual seal arrangement. The first seal is a double lip seal molded in an elastomeric rubber. The second / main seal shall be a unitized hard face silicone carbide seal with stainless steel housings and spring. The upper and lower bearing shall be capable of handling all radial thrust loads. The lower bearing shall have the additional ability to handle the downward axial thrust produced by the impeller by design of angular contact roller races. Machined pump components shall be concentric and parallel, thereby equalizing the pressures and forces experienced during operation, which will extend the service life of the seals, bearings, and rotating components. The pump shall be furnished with stainless steel handle having a nitrile grip.

4.01 ELECTRICAL POWER CORD

The submersible pump shall be supplied with 10 meters of multi-conductor power cord. It shall be cord type H07RN-F capable of continued exposure to the pumped liquid. The power cord shall be sized for the rated full load amps of the pump in accordance with the IEC 60335-1. The power cable enters the motor housing directly by means of a water tight compression fitting, with a cast iron cord plate, sealed to the housing by a Buna-N gasket. The power cord termination internal to the pump has been epoxied, to eliminate the ability of water to enter the pump housing through the cord, by means of wicking through a damaged cord insulation jacket. The power cord entry system shall carry an IP68 degree of protection.

5.01 MOTORS

All motors shall be class B insulated NEMA B design, oil cooled, rated for continuous duty. Single phase motors shall be capacitor start / capacitor run, controlled by an integral solid state starting circuit to switch the start winding off. The capacitors and solid state switch shall be mounted to the motor, internal to the pump housing. Single phase motors shall include an integral thermal overload device that prevents a maximum load winding temperature from exceeding 135 °C. Three phase motors shall be used with an appropriate controller with integral overload protection. Since air filled motors are not capable of dissipating heat they shall not be considered equal.

6.01 BEARINGS AND SHAFT

The upper bearing shall be a radial type, single ball / race type bearing. The lower bearing shall be a thrust type, angular contact heavy duty ball / race type bearing, designed to handle axial pump thrust loads. Both bearings shall be open type, exposing the balls and races for permanent lubrication by the oil internal to the motor housing. The motor shaft shall be made of 300 or 400 series stainless steel and have a minimum diameter of .670".

7.01 SEALS

The pump shall have a dual seal arrangement consisting of a lower and upper seal to protect the motor from the pumping liquid. The lower seal shall be an elastomeric rubber molded lip seal, designed to exclude foreign material away from the main upper seal. The upper seal shall be a unitized silicon carbide hard face seal with stainless steel housings and spring equal to Crane Type T-6a. The motor plate / housing interface shall be sealed with a Buna-N O-ring.

8.01 IMPELLER

The impeller shall be a class 25 cast iron 2 vane impeller, with pump out vanes on the back shroud to keep debris away from the seal area. The impeller shall be mounted to the motor shaft via a threaded connection, secured against loosening with a bonding agent.

9.01 CONTROLS

All FL200-E series pumps must be operated by means of control panel. Control panel components must comply with national and local electrical codes, and be set using the pump electrical ratings to function properly.

10.01 PROTECTIVE COATING

The exterior of the casting shall be protected with Powder Coat Epoxy.

11.01 SUPPORT

The pump shall have cast iron support legs, enabling it to be a free standing unit. The legs will be high enough to allow 3/4" solids handling.

12.01 FACTORY ASSEMBLED TANK SYSTEMS WITH GUIDE RAIL AND QUICK DISCONNECT DISCHARGE

_____ Guide factory mounted rail system with pump suspended by means of thread on quick disconnect which is sealed by means of Buna-N grommets or O-rings. The Discharge piping shall have a check valve. The Discharge piping shall be schedule 80 PVC and furnished with a PVC shut-off ball valve. The Tank shall be wound fiberglass or roto-molded plastic. An inlet hub shall be provided with the fiberglass systems.

_____ Stainless steel Guide Rail

_____ Zinc plated steel Guide Rail

_____ mm diameter of basin size

_____ mm height of basin size

_____ mm distance from top of tank to discharge pipe outlet

_____ Fiberglass cover

_____ Structural foam polymer cover

_____ Steel cover

_____ Simplex System with Outdoor panel and alarm

_____ Duplex System with Outdoor panel and alarm

_____ Separate Outdoor Alarm

_____ Remote Outdoor Alarm

13.01 TESTING

The pump shall have an earth continuity check and the motor chamber shall be submitted to an electrical strength test, to test for electrical integrity, moisture content and insulation defects. The motor and volute housing shall be pressurized, and an air leak decay test is performed to ensure integrity of the motor housing. The pump shall be run where, the voltage and current is monitored, and checked for noise or other malfunction.

14.01 QUALITY CONTROL

The pump shall be manufactured in an ISO 9001 certified Facility.

15.01 WARRANTY

Standard limited warranty shall be 3 years.